

NOTE: Certain press applications may require guarding. Because of the multitude of possible press uses, it is impossible to design a guard that will meet every customer need. The end user must provide his own guarding where the situations dictate.

IMPORTANT SAFETY INFORMATION:

Power Team has protective blankets available which may afford protection from injury to users and others should part breakage occur. Power Team recommends the use of these blankets for all pushing, pulling, pressing, and lifting applications. See page 139 for additional information.

7 Horizontal pressing capabilities

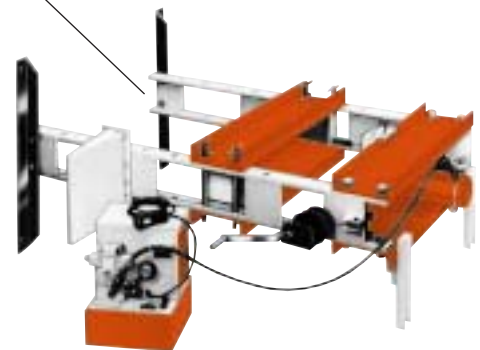

1 2 TO 1 SAFETY FACTOR on hydraulic cylinders and they meet ASME B30.1 standards. Cylinders are easily removed for other applications. Single- or double-acting cylinders are available; built-in relief valve on double-acting cylinders.

2 FULL RATED CAPACITY across width of upper frame, even with workhead moved to one side. (Heavy-duty presses only.)

3 LARGER WORK AREA than most competitors' models.

4 ALIGNMENT LEVER for simple pin replacement after raising or lowering the bed.

5 CLOSE MANUFACTURING TOLERANCE allows even load distribution over four alloy steel pins; not two, like some competitors. (Heavy-duty presses only.)

6 OPEN THROAT® FEATURE on 25 ton press provides additional work area by mounting cylinder on outside for C-frame advantage.

7 FRAMES CAN BE USED HORIZONTALLY for pressing jobs on extra-long shafts (see photo above).

8 ELECTRIC, AIR OR HAND HYDRAULIC PUMPS are available. All are standard Power Team pumps.

CSA approved electric pumps are standard on all presses.

Externally adjustable relief valve for precise operator control of working pressure is standard on all electric pumps except PE10 and PE17 series.

24 volt hand switch for remote control on pumps equipped with solenoid valves.

9 ONE-MAN OPERATION for bed adjustment. Winch unit quickly raises or lowers bed to desired height. Self-locking winch mechanism prevents bed from dropping when handle is released.

10 3/8" I.D. HOSE on spring return cylinders on heavy-duty presses provides up to six times faster cylinder return than standard 1/4" I.D. hose.

11 FAST CYLINDER APPROACH to work provided by 2-speed hand, air or electric pumps.

12 RUGGED UPRIGHTS, 50 percent stronger than channel iron. Four post design means open side for easy loading of long material.

NOTE: Certain features do not apply to Power Team 10 ton, Roll-Bed, or economy presses.

Bench/Floor H Frame Presses

10 Ton Capacity

SHOP EQUIPMENT

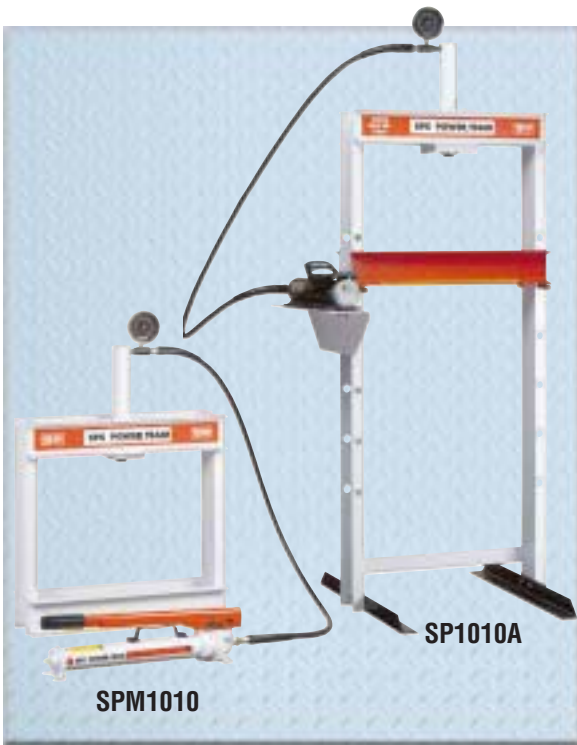

- Ideal for small pressing jobs; repairing small motors, armatures, removing and installing gears, bearings, other press-fit parts.
- Bench press has 15³/₈" x 18" work area; floor press bed height is adjustable from 5" to 41" with horizontal "daylight" of 21".
- Choices of power sources: single-speed hand pump, electric/hydraulic or air/hydraulic.
- Hydraulic gauges, hoses and fittings included.
- PUMP ELECTRICAL SPECIFICATIONS
PE10 Series – ¼ hp, 115 volt, 60 cycle, single phase. Also available in 230 volt, 50 cycle, add suffix "-220" to order number.



DIMENSIONS

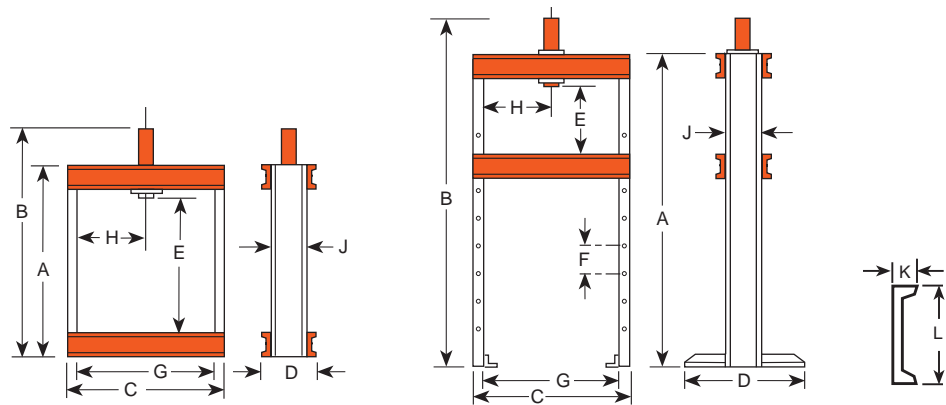

Frame	A (in.)	B (in.)	C (in.)	D (in.)	E (in.)	F (in.)	G (in.)	H (in.)	J (in.)	K (in.)	L (in.)	Bench Space (in.)	Floor Space (in.)
Bench	24½	33½	25¼	7¾	15½	—	22	11	4	1⅙	4	7¾ x 25¼	—
Floor	59	67½	25¼	28	5-41	6	22	2½-18½*	4	1⅙	4	—	28 x 28¼

* Lateral head movement

ORDERING INFORMATION

Frame	Cap. (tons)	Type of Cyl. Used	Stroke	Cylinder Model	Order No.	Speed (in./min.)†††		Type Pump	Pump Model †	Prod. Wt. (lbs.)
						Advance	Pressing			
222481 Bench	10	Single-Acting	10½"	C1010C	SPM1010	.06 in./stroke		Hand	P55	91
222480 Floor	10	Double-Acting	10"	C1010C	SPH1010	.06 in./stroke		Hand	P55	171
222480 Floor	10	Double-Acting	10"	C1010C	SPE1010	0.2	2.2	Elec. ††	PE102	175
222480 Floor	10	Double-Acting	10"	RD1010	SP1010A	0.3	3.7	Air	PA9H	162
222480 Floor	10	Double-Acting	10"	RD1010	SPE1010D	0.2	2.2	Elec. ††	PE104	192

† Optional air/hydraulic pumps available on request.

†† "Advance" position holds pressure with motor shut off. "Return" position advances cylinder with motor running and returns cylinder with motor shut off.

††† Typical performance based on 100 psi and 10,000 psi pump specifications. Actual speeds may vary with operating conditions.

C Frame Press 25 Ton Capacity



- Can be bench mounted or mounted on optional pedestal base.
- Bench mounted version requires less than 1.5 sq. ft. of space; on optional pedestal, only 4 sq. ft. of floor space is needed.
- “Open Throat” design makes loading and unloading of work easy.
- Cylinder head adjusts to three convenient working positions, providing up to 20 1/4" of “daylight.”
- Hydraulic cylinder delivers a 6 1/4" stroke, is driven by a P59 two-speed hand pump.
- **PEDESTAL BASE NO. 60846**
This optional pedestal provides a stable base for your SPM256C. It takes up only about 4 sq. ft. of space and includes a bracket for mounting the pump on the side of pedestal press. It must be ordered separately. Wt., 76 lbs.



SHOP EQUIPMENT

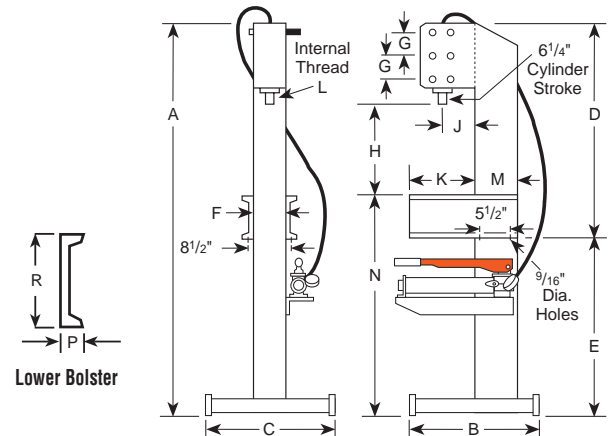

DIMENSIONS

A (in.)	B (in.)	C (in.)	D (in.)	E (in.)	F (in.)	G (in.)	H (Cyl. Retracted) (in.)
77 5/8	24 1/2	24	41 5/8	36	6	5	10 1/4, 15 1/4, 20 1/4

J (in.)	K (in.)	L (in.)	M (in.)	N (in.)	P (in.)	R (in.)	Floor Space (in.)
6 1/2	12 1/2	1 1/2 - 16	8	43	2	7	24 x 24 1/2

ORDERING INFORMATION

Cap. (tons)	Type Cyl. Used	Stroke	Cyl. Model	Order No.	Speed**		Type Pump	Pump Model	Prod. Wt. (lbs.)
					Advance	Pressing			
25	Single-Acting	6 1/4"	C256C	SPM256C*	.129 in./stroke	.03 in./stroke	Hand	P59	240

* SPM256C does not include No. 60846 pedestal base.

** Typical performance based on pump specifications. Actual speeds may vary with operating conditions.

H Frame "Open Throat" & "Economy" Presses

25 Ton Capacity

SHOP EQUIPMENT



OPEN THROAT PRESSES

- Design permits use as both "H" frame and "C" frame press; hydraulic cylinder can be mounted on frame extensions to handle jobs which won't fit between uprights.
- Open throat press models are also available with remote control to enable the operator to view work from all sides with finger tip control of cylinder piston travel.
- Moveable workhead for off-center pressing loads of full capacity can be applied across entire width of frame.

Press Accessories Page 167



ECONOMY PRESSES

- Rugged, yet reasonably priced. Handles many "big press" tasks, and perfect for many of the "in-between" jobs you see almost daily. (Note: stroke length limited to 6 1/4" on economy models.)

FEATURES OF BOTH OPEN THROAT AND ECONOMY PRESSES

- Press bed height easily adjustable with winch's bed will not drop when handle is released.
- Choice of power sources for rapid cylinder advance: two-speed hydraulic hand pump, electric/hydraulic or air/hydraulic.

PUMP ELECTRICAL SPECIFICATIONS

PE17 Series – 1/2 hp, 115 volt, 60 cycle, single phase.

PE21 Series – 1 hp, 115 volt, 60 cycle, single phase.

Both pumps available in 230 volt, 50 cycle, add suffix "-220" to order no.

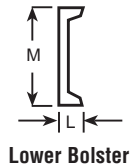

Lower Bolster

DIMENSIONS

A (in.)	B (in.)	C (in.)	D* (in.)	E (in.)	F (in.)	G (in.)	H (in.)	J (in.)	K (in.)	L (in.)	M (in.)	Floor Space (in.)
68	43	28	3 - 29	6 7/8 - 43 3/8	4 1/2	32	5 1/2	6 1/2	7	2 1/2	8	43 x 28

* Lateral head movement

ORDERING INFORMATION "OPEN THROAT" PRESSES

Cap. (tons)	Type of Cylinder Used	Stroke	Cylinder Model	Order No.	Speed (in./min.)†††		Type Pump	Valve Type	Pump‡ Model	Prod. Wt. (lbs.)
					Advance	Pressing				
25	Single-Acting	14 1/4"	C2514C	SPA2514	9.8	1.2	Air	2-Way Foot	PA6	683
25	Single-Acting	14 1/4"	C2514C	SPM2514	.49 in./stroke	.03 in./stroke	Hand	Load-Release	P159	693
25	Single-Acting	14 1/4"	C2514C	SPE2514	46.6	3.3	Elec.	2-Way††	PE172	665
25	Single-Acting	14 1/4"	C2514C	SPE2514S	52	4.0	Elec.	3-Way†	PE213S	759
25	Double-Acting	14 1/4"	RD2514	SPE2514DS	52	4.0	Elec.	4-Way†	PE214S	787

ORDERING INFORMATION "ECONOMY" PRESSES

Cap. (tons)	Type of Cylinder Used	Stroke	Cylinder Model	Order No.	Speed (in./min.)†††		Type Pump	Valve Type	Pump‡ Model	Prod. Wt. (lbs.)
					Advance	Pressing				
25	Single-Acting	6 1/4"	C256C	SPA256	9.8	1.2	Air	2-Way Foot	PA6	578
25	Single-Acting	6 1/4"	C256C	SPM256	.129 in./stroke	.129 in./stroke	Hand	Load-Release	P59	595
25	Single-Acting	6 1/4"	C256C	SPE256	46.6	3.3	Elec.	2-Way††	PE172	607

† Solenoid valve with 24 volt remote control hand switch.

†† Holds pressure with motor shut off. Also has an automatic dump setting. Furnished with a 10' remote motor control.

††† Typical performance based on 100 psi and 10,000 psi pump specifications. Actual speeds may vary under operating conditions.

‡ Pump standard with press. Other Power Team pumps can be substituted.

dBA at idle and 10,000 psi: PE172–67/81 dBA; PE21–70 dBA measured at 3 foot distance, all sides.

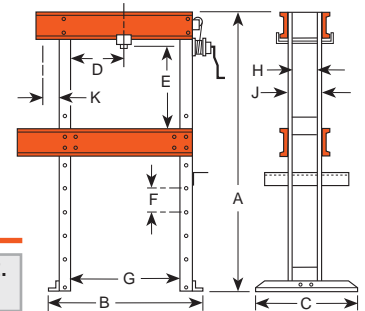

Open Throat feature enables cylinder to be mounted on outside of press frame for fast bearing removal and more.

H Frame Presses

55 Ton Capacity



- Movable workhead for full off-center pressing at full rated capacity across width of upper frame without buckling or bending.
- Maximum "daylight" is 42" x 36", making positioning of even bulky work pieces easy.

- Height of press bed is easily adjusted with winch; friction brake prevents bed from dropping and handle from spinning upon release.
- 55 ton cylinder has chrome plated piston rod and wiper seals to keep out corrosion and contamination in a shop environment.
- Presses with single-acting cylinder offer choice of 2-speed hand operated, electric/hydraulic, or air/hydraulic pump. Models with double-acting cylinder have an electric/hydraulic pump.
- Press model equipped with remote control enables operator to view work from all sides with fingertip control of cylinder piston travel.
- Press can be used horizontally for special applications with user-supplied support legs.

• PUMP ELECTRICAL SPECIFICATIONS

PE17 Series – ½ hp, 115 volt, 60 cycle, single phase. Also available in 230 volt, 50 cycle.

PE21 Series – 1 hp, 115 volt, 60 cycle, single phase. Also available in 230 volt, 50 cycle.

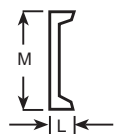

Lower Bolster

PQ60 Series – 2 hp, 230 volt, 60 cycle, single phase. Also available in 230 volt, 50 cycle.

To order presses with 230 volt, 50 cycle pumps, add suffix "-220" to order no.

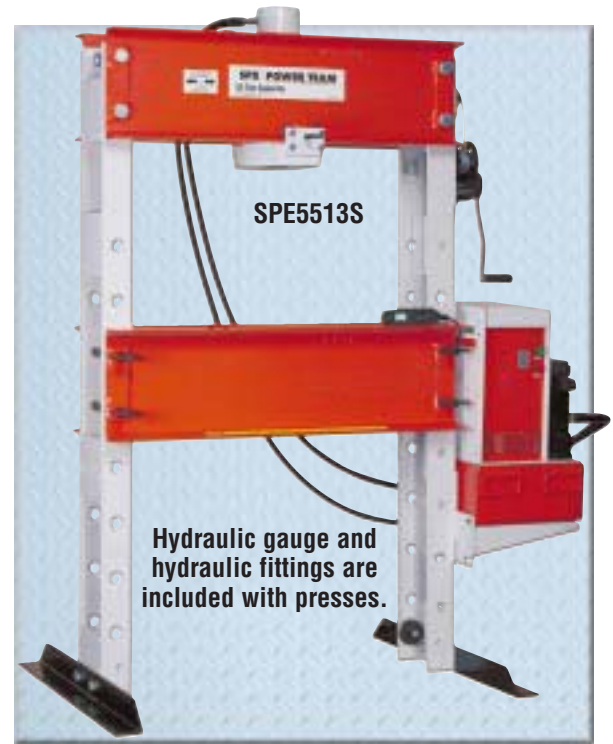

Hydraulic gauge and hydraulic fittings are included with presses.

SHOP EQUIPMENT

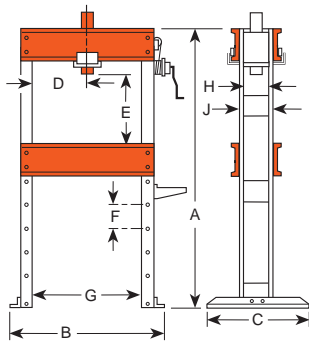

DIMENSIONS

A (in.)	B (in.)	C (in.)	D* (in.)	E (in.)	F (in.)	G (in.)	H (in.)	J (in.)	L (in.)	M (in.)	Floor Space (in.)
72	48½	36	3¼- 32¾	6 - 42	6	36	6¾	8	3	12	48½ x 36

* Lateral head movement

ORDERING INFORMATION

Cap. (tons)	Type of Cylinder Used	Stroke	Cylinder Model	Order No.	Speed (in./min.)†††		Type Pump	Valve Type	Pump‡ Model	Prod. Wt. (lbs.)
					Advance	Pressing				
55	Single-Acting	6¼"	C556C	SPA556	4.5	.5	Air	2-Way Foot	PA6	804
55	Single-Acting	6¼"	C556C	SPM556	.23 in./stroke	.015 in./stroke	Hand	Load-Release	P159	814
55	Single-Acting	13¼"	C5513C	SPM5513	.665 in./stroke	.026 in./stroke	Hand	2-Way	P460	960
55	Single-Acting	6¼"	C556C	SPE556	21.7	1.5	Elec.	2-Way††	PE172	836
55	Single-Acting	13¼"	C5513C	SPE5513	21.7	1.5	Elec.	2-Way††	PE172	980
55	Single-Acting	13¼"	C5513C	SPE5513S	24.4	1.9	Elec.	3-Way†	PE213S	1,056
55	Double-Acting	13⅞"	RD5513	SPE5513D	21.7	1.5	Elec.	4-Way	PE174	993
55	Double-Acting	13⅞"	RD5513	SPE5513DS	66.1	5.4	Elec.	4-Way†	PQ604S	1,114

* Frame is shipped assembled.

† Solenoid valve with 24 volt remote control hand switch.

†† Holds pressure with motor shut off. Also has an automatic dump setting. Furnished with a 10' remote motor control.

††† Typical performance based on 100 psi and 10,000 psi pump specifications. Actual speeds may vary with operating conditions.

‡ Pump standard with press. Other Power Team pumps can be substituted. dBA at idle and 10,000 psi: PE172—67/81; PE21 Series—70; PQ60—74/76; measured at 3 foot distance, all sides.



SF50

No. SF50 – Straightening fixtures for use with 55-ton shop or 80-ton Roll-Bed® presses (2 ea.). Wt., 104 lbs. **Not part of press, order separately.**

H Frame Presses

100 Ton Capacity

SHOP EQUIPMENT



- Cylinder workhead glides across upper frame on rollers, locks in place for off-center pressing jobs. Press may be used horizontally for special pressing applications with user-supplied supports.
- Press bed is raised and lowered by winch which locks in place for insertion of bed retaining pins. Upper bolster can be lowered 8" for convenient positioning on repetitive jobs.
- Generous "daylight" of 42" x 50" accommodates bulky work pieces, uprights are placed for easy side entry of bars or shafts for straightening or bending.
- Choice of single- or double-acting cylinder. Hydraulic pump options include: 2-speed hand pump with large 2 gallon reservoir, PE172 electric/ hydraulic pump or "PQ" series "Quiet" electric/hydraulic pump with low noise level.
- **PUMP ELECTRICAL SPECIFICATIONS**
PE17 Series – ½ hp, 115 volt, 60 cycle, single phase. **Also available in 230 volt, 50 cycle, add suffix "-220" to order no.**
PQ60 Series – 2 hp, 230 volt, 60 cycle, single phase. **Available in 115 volt, 60 cycle and 230 volt, 50 cycle. To order 230 volt, 50 cycle, add suffix "-220" to order no. For 115 volt consult factory.**
PQ120 Series – 3 hp, 460 volt, 60 cycle, three phase. Available in 220/380 volt, 50 cycle. **To order 380 volt, 50 cycle, add suffix "-380" to order no.**

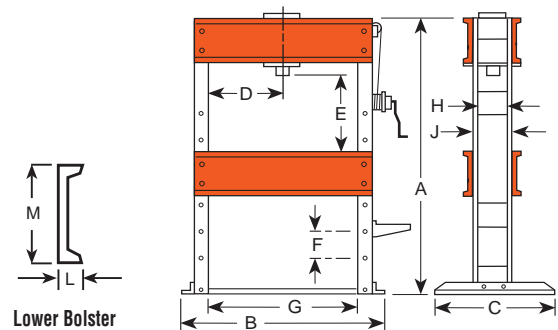

DIMENSIONS

A (in.)	B (in.)	C (in.)	D* (in.)	E (in.)	F (in.)	G (in.)	H (in.)	J (in.)	L (in.)	M (in.)	Floor Space (in.)
77 ¼	64	36	7 - 43	2 - 42	8	50	8	10	3 ⅞	15	36 x 78 ¼

* Lateral head movement

ORDERING INFORMATION

Cap. (tons)†	Type of Cyl. Used	Stroke	Cylinder Model	Order No.	Speed (in./min.)††		Type Pump	Valve Type	Pump‡ Model	Prod. Wt. (lbs.)
					Advance	Pressing				
100	Single-Acting	10 ¼"	C10010C	SPM10010	.356 in./stroke	.01 in./stroke	Hand	3-way	P460	1,698
100	Single-Acting	10 ¼"	C10010C	SPE10010	35	2.9	Elec.	3-way	PQ603	1,795
100	Single-Acting	10 ¼"	C10010C	SPE10010R	11.5	.8	Elec.	2-way	PE172	1,690
100	Double-Acting	13 ⅞"	RD10013	SPE10013DS	35	5.8	Elec.	4-Way*	PQ1204S	1,886

† Frame is shipped assembled. *Solenoid valve with 24 volt remote control hand switch.

†† Typical performance based on 100 psi and 10,000 psi pump specifications. Actual speeds may vary under operating conditions.

‡ Pump standard with press. Other Power Team pumps can be substituted.

dBa at idle and 10,000 psi: PE172—67/81; PQ60—74/76; PQ120—73/78. Measured at 3 foot distance, all sides.



H Frame Presses

150 and 200 Ton Capacity

Press
Accessories
Page
167



- Standing 7½ feet tall, these giants handle the really big jobs. May be used horizontally for special pressing applications with user-supplied supports.
- Workhead has wide horizontal travel; rugged

press frame withstands load of rated capacity across full width of frame.

- Winch mechanism provides easy positioning of press bed, locks in place for insertion of retaining pins. Upper bolster can be lowered 11" for convenient positioning on repetitive jobs.
- Uprights are placed for easy side entry of bars or shafts for straightening or bending.
- Fast cylinder approach is provided by PQ1204S "Quiet" electric/hydraulic pump. Has remote control hand switch, enabling operator to view work from all sides with fingertip control of cylinder piston travel.

• PUMP ELECTRICAL SPECIFICATIONS

PQ120 Series – 3 hp, 460 volt, 60 cycle, three phase. **Also available in 220/380 volt, 50 cycle, add suffix "-380" to order no.**

NOTE: To order press with 230 volt, 60 cycle, single phase pump, order press less PQ1204S. Order pump No. PQ604S separately.



SHOP EQUIPMENT

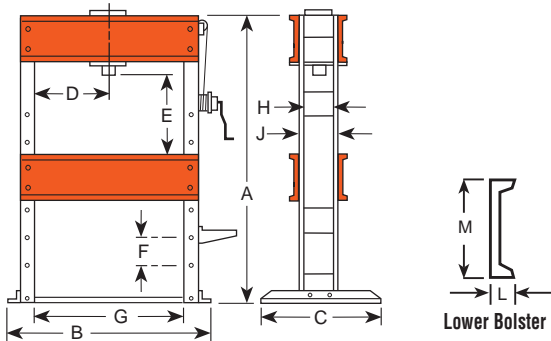

DIMENSIONS

A (in.)	B (in.)	C (in.)	D* (in.)	E (in.)	F (in.)	G (in.)	H (in.)	J (in.)	L (in.)	M (in.)	Floor Space (in.)
90	71	44	11 - 39	9 - 43 ³ / ₄	11	50	12 ¹ / ₂	15	4 ¹ / ₈	18	44 x 71

* Lateral head movement

ORDERING INFORMATION

Capacity (tons)†	Type of Cylinder Used	Stroke	Cylinder Model	Order No.	Speed (in./min.)††		Type Pump	Valve Type	Pump Model***	Prod. Wt. (lbs.)
					Advance	Pressing				
150	Double-Acting	13 ¹ / ₈ "*	RD15013	SPE15013DS	24	3.9	Electric*	4-way**	PQ1204S	3,015
200	Double-Acting	13 ¹ / ₈ "*	RD20013	SPE20013DS	18	2.9	Electric*	4-way**	PQ1204S	3,276

† Frame is shipped assembled.

†† Typical performance based on 100 psi and 10,000 psi pump specifications. Actual speeds may vary under operating conditions.

* Pre-wired at factory for 460V.

** Solenoid valve with 24 volt remote control hand switch.

*** Pump standard with press. Other Power Team pumps can be substituted. dBA at idle and 10,000 psi: 73/78, measured at 3 foot distance, all sides.

H Frame "Roll Bed" Presses

80, 100, 150, 200 Ton Capacity

SHOP EQUIPMENT



RB10013S

Hydraulic gauge and hydraulic fittings are included with presses.

- The original, patented Roll-Bed® design. Bed rolls out for easy loading and unloading with a crane or other lifting device.
- Movable workhead glides easily side-to-side for full off-center load capacity across width of upper frame.
- "Daylight" is 50½" x 60" for 80 and 100 ton models; 51¼" x 64" on 150 and 200 ton presses.
- Fast approach of double-acting, 13½" stroke cylinder is provided by PQ1204S "Quiet" electric/ hydraulic pump with remote control hand switch. Operator can view work from all sides with fingertip control of cylinder piston travel.

Press
Accessories
Page
167



PRESS FEATURES:

- **Roll-Bed® design**
Bed glides in or out on bearings to make loading and unloading fast, easy.
- **Adjustable lower bed width**
For secure balancing and centering of heavy jobs. Loosen adjusting bolts to adjust bed from 4" to more than 27". See dimension "H".
- **Movable workhead**
For off-center pressing jobs, workhead moves on bearings across upper bolster. Presses can be used at full capacity, regardless of where workhead is placed.
- **Lifting mechanism**
Simply turn crank handle to raise or lower upper bolster. Screw mechanism raises or lowers both sides evenly (a heavy duty ½" drill motor can replace handle for automatic adjustment). Four locking pins hold bolster in place for pressing.
- **Optional heavy-duty straightening fixtures**
Make straightening jobs easy and accurate to within .004"! Rollers are ball bearing mounted and handle raises or lowers for easy turning of the work.

PUMP ELECTRICAL SPECIFICATIONS

PQ120 Series – 3 hp, 460 volt, 60 cycle, three phase. **Available in 220/380 volt, 50 cycle, add suffix "-380" to order no.**

NOTE: To order press with a 230 volt, 60 cycle, single phase pump, order press less PQ1204S. Order pump No. PQ604S separately.

NOTE: Different voltage and valve options can be obtained by substituting certain PA, PE or PQ series pumps. Consult the factory.

Heavy-duty Straightening Fixtures



No. SF50 – Fixtures for use with 80 ton Roll-Bed presses or 55 ton heavy-duty shop presses. (2 ea.). Wt. 104 lbs. **Not part of press, order seperately.**



No. SF150 – Fixtures for use with 100, 150 and 200-ton Roll-Bed presses and 100 ton shop presses only (1 pr.). Wt. 196 lbs. **Not part of press, order seperately.**



Cylinder is easily moved across width of upper bolster.

Width adjusts from 4" to over 27"; is secured with locking bolts.



Lifting screw and locking pins make bolster raising a one-man job.



Bearings make bed positioning smooth and easy.



Lever lowers bed for pressing, raises it for rolling.

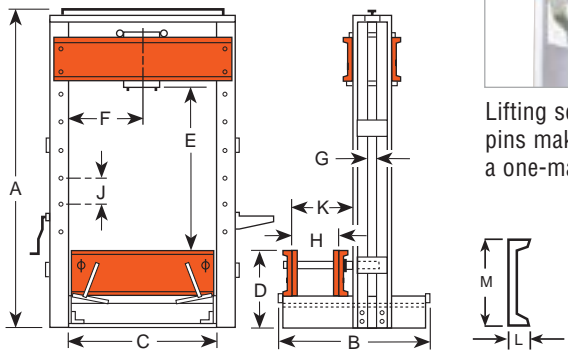

Lower Bolster

DIMENSIONS

Cap. Tons	A (in.)	B (in.)	C (in.)	D (in.)	E (in.)	F (in.)	G (in.)	H (in.)	J (in.)	K (in.)	L (in.)	M (in.)	Floor Space (in.)
80	112 ⁵ / ₈	64 ¹ / ₄	50 ¹ / ₂	27	12 - 60	14 ¹ / ₂ - 36	3	4 - 27 ¹ / ₄	8	36 ¹ / ₂	3 ³ / ₈	15	64 ¹ / ₄ x 60 ¹ / ₂
100	112 ⁵ / ₈	64 ¹ / ₄	50 ¹ / ₂	27	12 - 60	14 ¹ / ₂ - 36	3	4 - 27 ¹ / ₄	8	36 ¹ / ₂	3 ³ / ₈	15	64 ¹ / ₄ x 60 ¹ / ₂
150	123 ¹ / ₄	68 ¹ / ₄	51 ¹ / ₄	30	9 - 64	13 ⁷ / ₈ - 37 ³ / ₈	3	4 - 27 ¹ / ₈	11	37 ¹ / ₄	4 ¹ / ₈	18	68 ¹ / ₄ x 63 ¹ / ₄
200	123 ¹ / ₄	68 ¹ / ₄	51 ¹ / ₄	30	9 - 64	15 ¹ / ₈ - 36 ³ / ₈	3	4 - 27 ¹ / ₈	11	37 ¹ / ₄	4 ¹ / ₈	18	68 ¹ / ₄ x 63 ¹ / ₄

ORDERING INFORMATION

Capacity (tons)†	Type of Cylinder Used	Stroke	Cylinder Model	Order No.	Speed (in./min.)††		Type Pump	Valve Type	Pump‡ Model	Prod. Wt. (lbs.)
					Advance	Pressing				
80	Double-Acting	13 ¹ / ₈ "	RD8013	RB8013S	46	7.5	Elec.	4-way*	PQ1204S	2,886
100	Double-Acting	13 ¹ / ₈ "	RD10013	RB10013S	35	5.8	Elec.	4-way*	PQ1204S	2,944
150	Double-Acting	13 ¹ / ₈ "	RD15013	RB15013S	24	3.9	Elec.	4-way*	PQ1204S	4,458
200	Double-Acting	13 ¹ / ₈ "	RD20013	RB20013S	18	2.9	Elec.	4-way*	PQ1204S	4,546

* Solenoid valve with 24 volt remote control hand switch.

† Frame is shipped assembled.

‡ Pump standard with press. Other Power Team pumps can be substituted. dBA at idle and 10,000 psi: PQ120-73/78; measured at 3 foot distance, all sides.

†† Typical performance based on 100 psi and 10,000 psi pump specifications. Actual speeds may vary with operating conditions.

Mobile Floor Cranes

2200-4400 lb. Capacity

SHOP EQUIPMENT

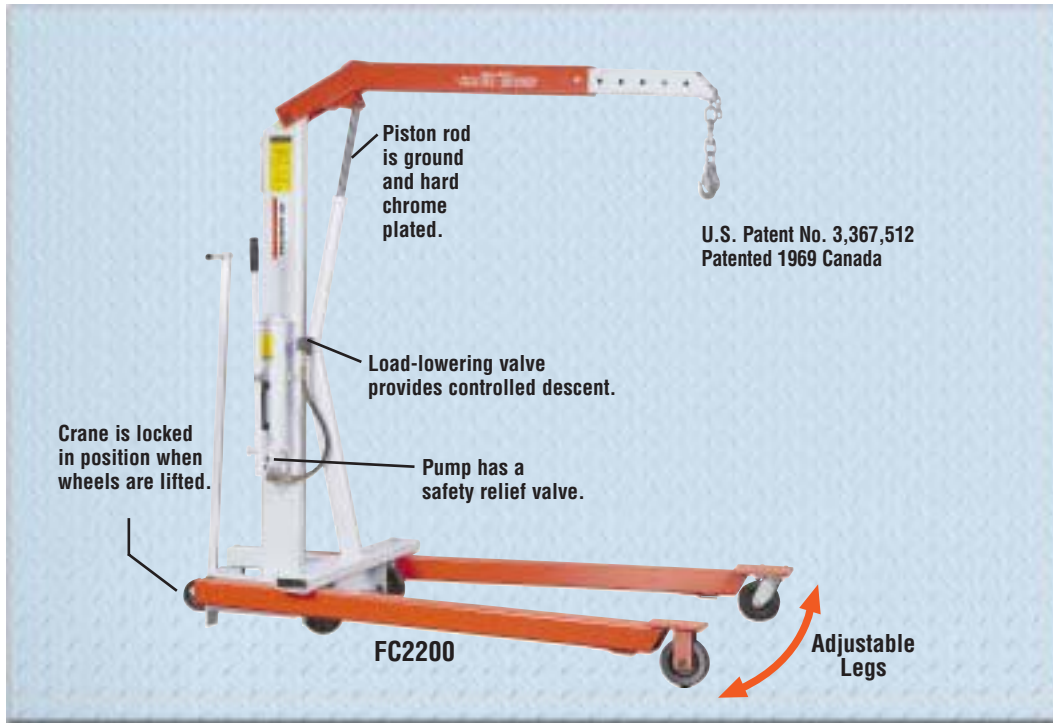

- Adjustable legs spread to clear obstacles, telescoping boom for extra reach. Rugged construction, reliable hydraulics.
- Boom collapses completely and legs fold for compact storage.
- 2-speed hydraulic hand pump provides fast boom travel and precise operator controlled descent.
- Roller bearing wheels and a steering dolly provide ease of mobility. Lifting chain is included.

ORDERING INFORMATION

No. FC2200 – 2,200 lb. cap. crane with fold-away feature, adj. leg spread, lifting chain and 2-speed hand pump. Wt., 471 lbs.

No. FC4400 – 4,400 lb. cap. crane with fold-away feature, adj. leg spread, lifting chain and 2-speed hand pump. Wt., 646 lbs.

DIMENSIONS (in.)

	FC2200*	FC4400*
Cap., boom ret. (lbs.)	2,200	4,400
Cap., boom ext. (lbs.)	1,650	3,300
A Max. boom hgt., (ret.)	107"	111"
B Max. boom hgt., (ext.)	117"	122"
C Overall hgt., boom horiz.	80"	82"
D Overall length	83"	89"
E Min. throat width	24"	25"
F Inside leg length	54"	57 1/2"
G Eff. boom reach (ret.)	33"	35 1/2"
H Eff. boom reach (ext.)	48"	50 1/2"
J Inside leg width	24" - 36" - 48" (3-position)	26" - 40" - 52 1/2" (3-position)
K Leg height	8"	9 1/2"
L Dolly wheel diameter	5"	5"
M Wheel diameter	6"	8"
N Caster diameter	6"	6"
Floor space, folded	27" x 38"	31" x 42"
Height, folded	79"	86"

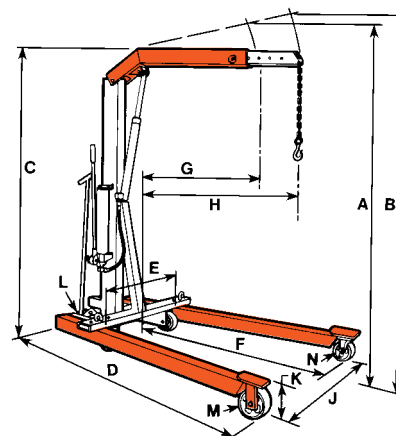

2,200 lb. and 4,400 lb. capacity with space-saving fold-away feature



* Frame shipped unassembled.

Load-Rotors®/Tilters

2000-6000 Ton Capacity

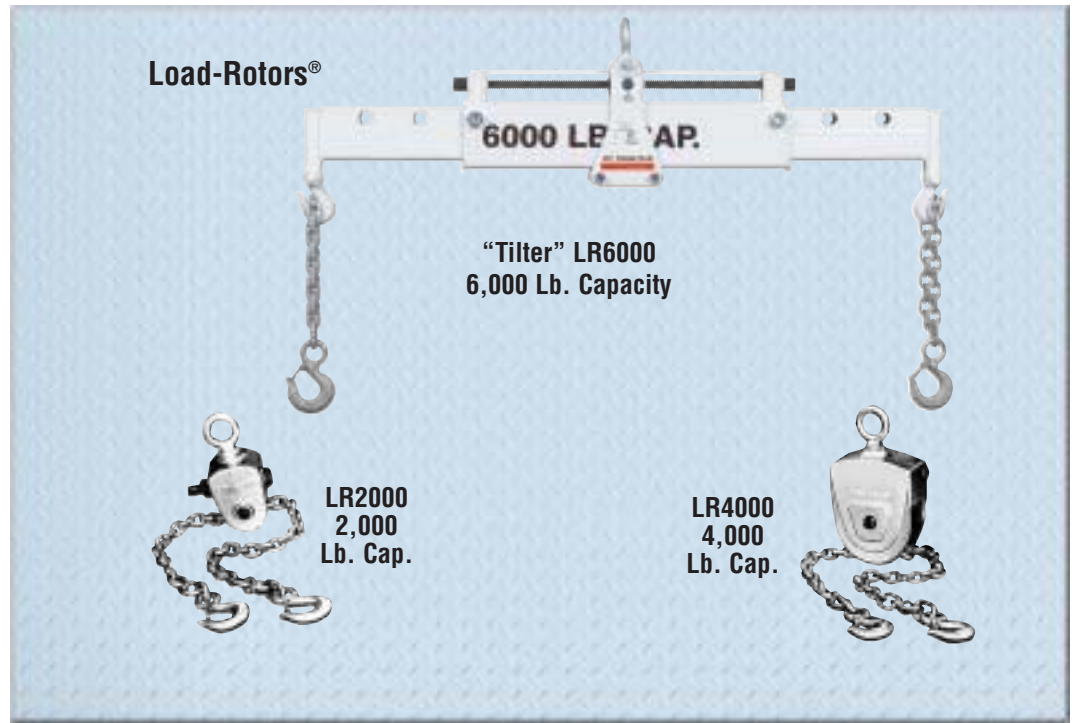

SHOP EQUIPMENT

- For lifting or positioning components, Power Team's heavy duty lifting slings are just right.
- The heavy duty Load-Rotors, when used with a crane or hoist, greatly reduce time and effort.
- A self-locking worm and gear set in the Load-Rotor head permits rapid angle adjustment of the component being handled.
- Whenever you have big, heavy components to move or position, nothing helps you get the job done easier and faster than the 6,000 lb. "Tilter".

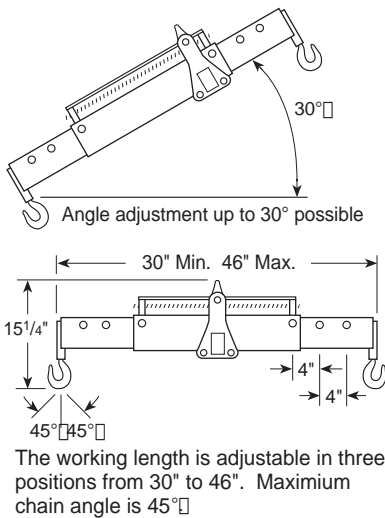

ORDERING INFORMATION

Capacity (lbs.)	Order No.	Chain Size (in.)	Chain Lg. W/ Swivel Hooks (in.)	Lifting Eye Opening (in.)	Hex Drive End (in.)	Gear Ratio	Product Wt. (lbs.)
2000	LR2000	1/4	56	1 1/4	5/8	34:1	9
4000	LR4000	5/16	65	1 3/4	5/8	82:1	23
6000	LR6000	5/16	65	1 5/8	5/8	82:1	73